

250 Series with Stepper Motor

Specification sheet 2015



- Clamshell design
- Easy tube change
- Clip on pump head
- 4 or 6 roller options
- Anti-tamper locking screw
- Sprung tube grips
- Stepper motor driver options

The 250 series stepper motor pump is designed for accurately dispensing fluids. The tube can easily be changed by operating the lever which lifts the top part of the pump clear of the tube. The pump has sprung tube grips & is available with either 4 or 6 rollers (4 rollers will cause less wear and give a higher flow but 6 rollers will give a less pulsating flow). The pump can be supplied without a stepper driver or with a self pulsing SMA or SMB driver. The SMA has a built in miniature potentiometer suitable for very rarely adjusted speeds and the SMB can be speed controlled via an external 10K potentiometer or an external 0-5v signal.

Approximate flow rates: 1.6mm Bore tubing 0.19ml/rev (4 roller) - 0.17ml/rev (6 roller).
 3.2mm Bore tubing 0.66ml/rev - 0.5ml/rev. 4.8mm Bore tubing 1.25ml/rev - 0.83ml/rev.

Product Code generation

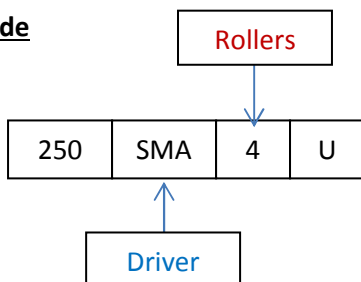

Driver	Product code
- No driver	SM
- SMA	SMA
- SMB	SMB
Number of rollers	
- 4	/4
- 6	/6

250-SMA/4U

This example product code relates to a 250 series pump, with an SMA driver, and 4 rollers.

Note: Pump is supplied as standard without tubing which should be ordered separately.

Williamson Manufacturing Company Ltd

The Street, Poynings, West Sussex, BN45 7AQ, United Kingdom.
 Tel +44(0)1273 857752 Fax +44(0)1273 857511 Web www.wmcpumps.com

Motor specification:

Step Angle	1.8°
Phase current	1.4A
Phase resistance	3.1Ω
Phase inductance	11mH
Number of leads	8

Wiring Details Bi-Polar parallel drive:

	Wire Colours
A+	White/Black & Orange
A-	White/Orange & Black
B+	White/Red & Yellow
B-	White/Yellow & Red

For pumps supplied with driver:

The drivers will be factory set to 1.4A and will be supplied with a low speed link giving a speed range of 0.15 to 153 RPM. To alter drive currents or speed ranges please refer to the SMA/SMB user manual available at www.wmcpumps.com/images/spec_sheets_pumps/250_user_manual.pdf. The pump can be stopped by removing the power or connecting 0v to Enable. We do not suggest stopping by connecting 0v to run/stop as this holds the pump in a powered condition. For best results we suggest running from a 24 to 30v DC supply. The SMB driver can be controlled via a 0-5v external signal but the 0v supply & 0v

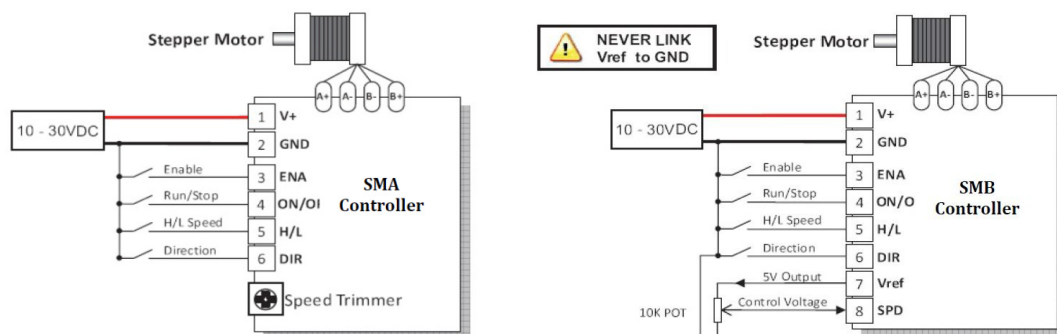

The pump head can be removed from the rest of the assembly by first **removing the locking screw** located behind where the tube sits (accessible once top part of the pump is raised) and then rotating the pump head anti clockwise on its bayonet fitting whilst pressing on the rectangular lever behind the pump head lift lever.

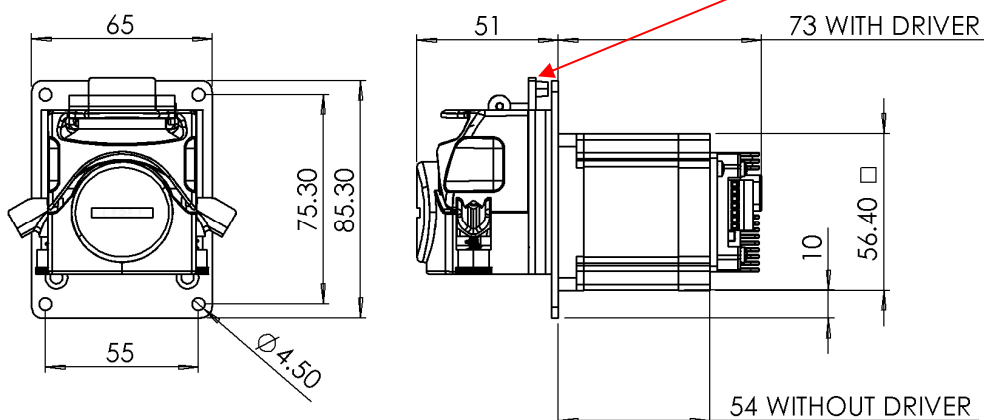

Williamson Manufacturing Company Ltd

The Street, Poynings, West Sussex, BN45 7AQ, United Kingdom.
 Tel +44(0)1273 857752 Fax +44(0)1273 857511 Web www.wmcpumps.com